

BEVELING EQUIPMENT | TOOL BITS + TRI TOOL + E.H. WACHS

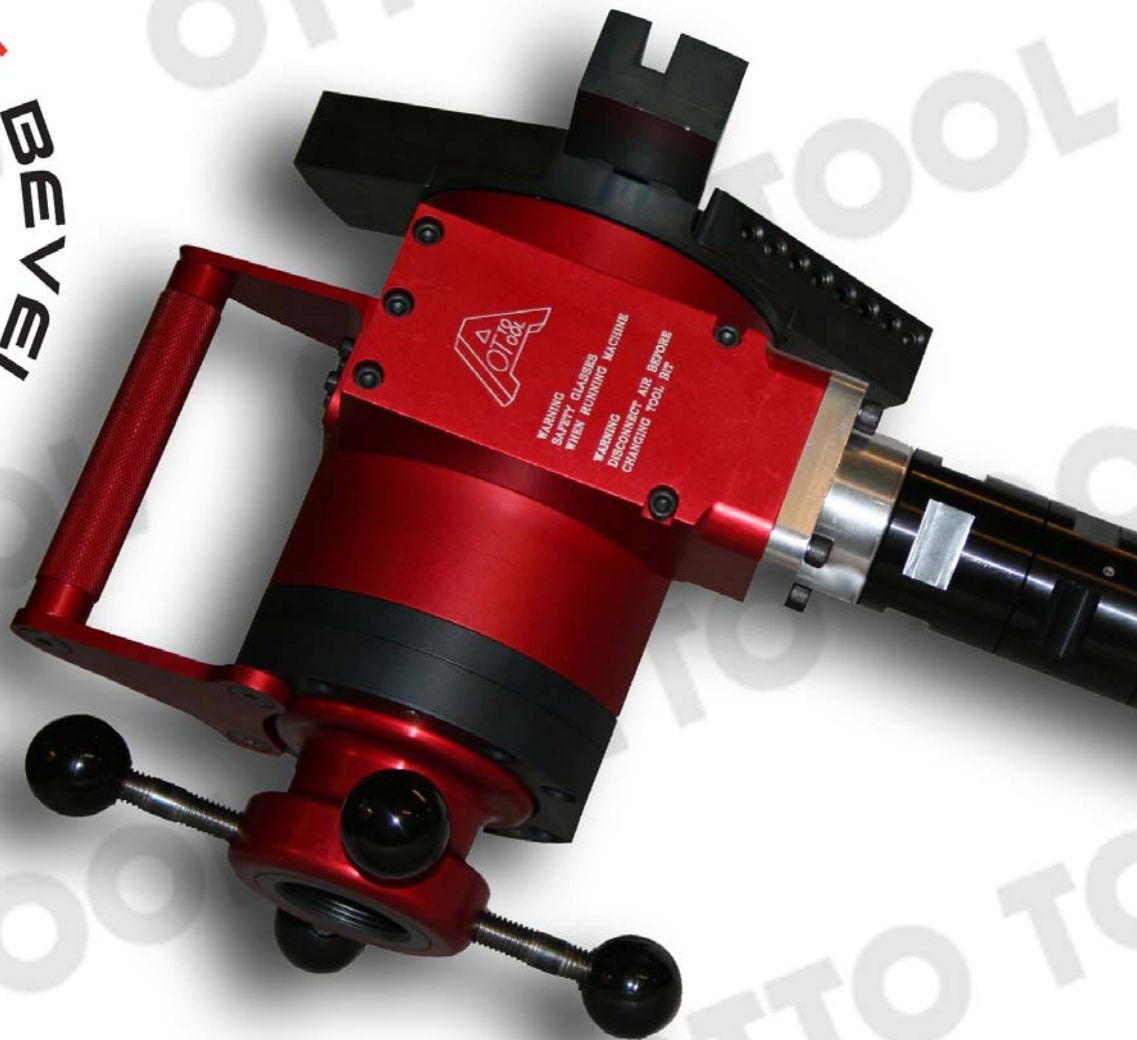

800-878-BITS (2487)



*Since 1988*

Dear Customer,

We at Otto Tool would like to thank you for your business for the past 20 years. We feel that 2008 will be a strong year in the Beveling Tool line for Otto Tool along with our Facing Tool line, plus with many new products and improvements to offer our customers. All of our employees are dedicated to your satisfaction and getting the best product at the best cost to your job site. Please take a few moments and look through our new catalog and discover our many new or improved products we now offer.

During 2007, we had our engineers working on new beveling tools to fill out our Beveling Machine product line. With our new Beveling Machine line, we can now offer a full range from 1" to 12" pipe.

Please check out our aftermarket cutting tool bits for most brand of beveling tools. You will find our pricing well below the competition and well stocked at our warehouse.

Thank you again for your business, we look forward to working with you and welcome any feedback that you may have. Your business is important to us.

Sincerely,

Alan Avis, President  
Otto Tool, Inc.

# OTTO TOOL

## BULLDOG BEVELING MACHINES

PBM 2500	2
PBM 4500	3
PBM 6000	4
PBM 8000	5
PBM 12	6

## TOOL BITS

Otto Tool Beveling Equipment	7
Tri Tool Beveling Equipment	8
E.H. Wachs Beveling Equipment	9

# BULLDOG BEVELING TOOL | PBM-2500

Size Range 1" (25.4mm) to 2-1/2" (63.5mm) Pipe  
.957 ID to 2.635 ID Weight approx: 16 lbs.

## Overview:

The Boiler Bull-Dog Beveling machine comes with a torque accepting mandrel that makes this lightweight portable I.D. tool perfect for beveling boiler tube or any close quarters space that most other beveling will not fit. This tool works with high speed tool steel bits, either a 3/8" thick tool bit with "wedge lock tool bit system" or 1/4" thick tool bit without our wedge lock system.



PBM-2500 Tool Bits (see page 7)

## Standard Features:

- Lock in mandrel blades (no springs to lose)
- Adjustable keyway on machine and mandrel to eliminate backlash and chatter
- 3/4 hp. Pneumatic motor, Air requires: 40 CFM and 90psi
- Light weight, just 16 lbs (working weight)
- Hardened mandrel - 55 Rc. (less chance of gouging with metal chips)
- Spiral bevel gears (more teeth engagement, compared to stand straight gears)
- Tool bits are held in by our wedge lock system (keeps the tool bit lock in the cutter head to ensure chatter free bevels)
- 2-1/2" wide X 10" long mandrel X 13-1/2" deep, will fit
- Carrying Case
- Single mandrel with blades to cover full size range

## OPTIONS:

Air Caddy - includes air regulator, filter & oil mister P/N: PBM-AF



Air Caddy - optional with all PBM machines

# BULLDOG BEVELING TOOL | PBM-4500

Size Range 1-1/4" (31.75mm) to 4" (101.60mm) Pipe  
1.278 ID. to 4.334 ID. Weight approx: 26 lbs.

## Overview:

This 4" pipe beveling machine comes with a torque accepting mandrel and is built with a worm gear drive unit for extra torque, to handle extra thick pipe walls. Our machine is one of the only machines on the market that can bevel, face, and counter-bore 1" wall. The pneumatic air motor is a 1-5/8 hp. Air required: 55 CFM and 90 psi.



PBM-4500 mounted to pipe

PBM-4500 Tool Bits (see page 7)

## Standard Features:

- Lock in mandrel blades (no springs to lose)
- Adjustable keyway on machine and mandrel to eliminate backlash and chatter
- 1-5/8 hp. Pneumatic motor, Air required: 55 CFM and 90psi.
- 26 lbs approx working weight
- Hardened mandrel- 55 Rc. (less chance of gouging with metal chips)
- Worm gear drive for extra torque when needed
- Three slots to do beveling, facing, deburring or counter-boring
- Carrying Case
- Single Mandrel with mandrel blades to cover full size range

## OPTIONS:

Air Caddy - includes air regulator, filter & oil mister

Flange Facing Machine - range 2-1/4" to 16"

*Note: Thin Wall Sleeves for thin wall tubing available*

P/N: PBM-AF

P/N: PBM-4FL



## BULLDOG BEVELING TOOL | PBM-6000

Size Range 2" (50.8mm) to 6" (152.4mm) Pipe  
2.067 ID. to 6.065 ID. Weight approx: 28 lbs.

### Overview:

This 6" pipe beveling machine comes with a torque accepting mandrel and is built with a worm gear drive unit for extra torque, to handle extra thick pipe walls. Our machine is one of the only machines on the market that can bevel, face, and counter-bore 1" wall. The pneumatic air motor is a 2 hp. Air required: 55 CFM and 90 psi.



### Standard Features:

- Lock in mandrel blades (no springs to lose)
- Adjustable keyway on machine and mandrel to eliminate backlash and chatter
- 2 hp. Pneumatic motor, Air required: 55 CFM and 90psi.
- 48 lbs approx working weight
- Hardened mandrel- 55 Rc. (less chance of gouging with metal chips)
- Worm gear drive for extra torque when needed
- Three slots to do beveling, facing, deburring or counter-boring
- Carrying Case
- Single Mandrel with mandrel blades to cover full size range

### OPTIONS:

Air Caddy - includes air regulator, filter & oil mister

Flange Facing Machine - range 4" to 24"

*Note: Thin Wall Sleeves for thin wall tubing available*

P/N: PBM-AF

P/N: PBM-4FL (Available July-08)

# BULLDOG BEVELING TOOL | PBM-8000

Size Range 3" (76.20mm) to 8" (203.2mm) Pipe  
2.624 ID. to 7.981 ID. Weight approx: 58 lbs.

## Overview:

This 8" pipe beveling machine comes with a torque accepting mandrel and a worm gear drive unit for extra torque, to handle extra thick pipe walls. Our machine is one of the only machines on the market that can bevel, face, and counter-bore 2" wall. The pneumatic air motor is a 3 hp. Air required: 70 CFM and 90 psi.



PBM-8000 Tool Bits (see page 7)

## Standard Features:

- Lock in mandrel blades (no springs to lose)
- Adjustable keyway on machine and mandrel to eliminate backlash and chatter
- 3 hp. Pneumatic motor, Air required: 70 CFM and 90psi.
- 58 lbs approx working weight
- Hardened mandrel- 55 Rc. (less chance of gouging with metal chips)
- Worm gear drive for extra torque when needed
- Three slots to do beveling, facing, deburring or counter-boring
- Carrying Case
- Single Mandrel with mandrel blades to cover full size range



PBM-8000 Mandrel

## OPTIONS:

Optional 2" to 3" mandrel with Mandrel Blades

Adapter Kit to Extend Pipe Size to 10"

Air Caddy - includes air regulator, filter & oil mister

Flange Facing Machine - range 4" to 24"

*Note: Thin Wall Sleeves for thin wall tubing available*

P/N: PBM-8920

P/N: PBM-8000-EXT

P/N: PBM-AF (Available July-08)

P/N: PBM-8FL

# BULLDOG BEVELING TOOL | PBM-12

Size Range 4" (76.20mm) to 12" (203.2mm) Pipe  
3.826 ID. to 12.250 ID. Weight approx: 74 lbs.

## Overview:

This 12" pipe beveling machine comes with a torque accepting mandrel and a worm gear drive unit for extra torque, to handle extra thick pipe walls. Our machine is one of the only machines on the market that can bevel, face, and counter-bore 2" wall. The pneumatic air motor is a 3 hp. Air required: 70 CFM and 90 psi.



PBM-12 Tool Bits (see page 7)

## Standard Features:

- Lock in mandrel blades (no springs to lose)
- Adjustable keyway on machine and mandrel to eliminate backlash and chatter
- 3 hp. Pneumatic motor, Air required: 70 CFM and 90psi.
- 74 lbs approx working weight
- Hardened mandrel- 55 Rc. (less chance of gouging with metal chips)
- Worm gear drive for extra torque when needed
- Three slots to do beveling, facing, deburring or counter-boring
- Carrying Case
- Single Mandrel with mandrel blades to cover full size range

## OPTIONS:

Optional 2" to 3" mandrel with Mandrel Blades  
Air Caddy - includes air regulator, filter & oil mister

P/N: PBM-8920

P/N: PBM-AF



## TOOL BITS FOR OTTO TOOL BEVELING EQUIPMENT

### PBM-2500

37-1/2 Degree Bevel Bit w/Lock wedge 3/8" thick	P/N: TB-5010
Facing Bit w/Lock Wedge 3/8" thick	P/N: TB-5011
37-1/2 Degree Bevel Bit 1/4" thick	P/N: TB-0333

### PBM-4500

37-1/2 Degree Bevel Bit 1-1/4" to 2" Pipe	P/N: TB-0167
37-1/2 Degree Bevel Bit 2" to 3-1/2" Pipe	P/N: TB-0333
37-1/2 Degree Bevel Bit 3" to 4" Pipe	P/N: TB-0944
37-1/2 Degree Heavy Duty Bevel Bit 2" to 3-1/2" Pipe	P/N: TB-0333-1
30 Degree Bevel Bit	P/N: TB-3030
45 Degree Bevel Bit	P/N: TB-1273
25-1/2 Degree J-Bevel Bit	P/N: TB-2566
Facing Bit .750" Tall for 1" to 2" Pipe	P/N: TB-0169
Facing Bit .875" Tall for 2" to 3" Pipe	P/N: TB-0257
Facing Bit 1.00" Tall for 3" to 4" Pipe	P/N: TB-0258
4 Degree Chamfer Bit	P/N: TB-0168

### PBM-6000, 8000 & PBM-12

37-1/2 Degree Bevel Bit Lower Range	P/N: TB-2905
37-1/2 Degree Bevel Bit Upper Range	P/N: TB-2906
30 Degree Bevel Bit Lower Range	P/N: TB-2930
30 Degree Bevel Bit Upper Range	P/N: TB-2931
45 Degree Bevel Bit Lower Range	P/N: TB-2913
45 Degree Bevel Bit Upper Range	P/N: TB-2914
J-Bevel Bit Lower Range	P/N: TB-2915
J-Bevel Bit Upper Range	P/N: TB-2916
Facing Bit	P/N: TB-2904
C-Bore 14.5 Degree Lower Range	P/N: TB-2907
C-Bore 14.5 Degree Middle Range	P/N: TB-2908
C-Bore 14.5 Degree Upper Range	P/N: TB-2909
C-Bore 10 Degree Lower Range	P/N: TB-2910
C-Bore 10 Degree Middle Range	P/N: TB-2911
C-Bore 10 Degree Upper Range	P/N: TB-2912

## TOOL BITS FOR TRI-TOOL BEVELING MACHINE

### 204 BEVELING MACHINE

37-1/2 Degree Bevel Bit 1-1/4" to 2" Pipe	P/N: TB-0167
37-1/2 Degree Bevel Bit 2" to 3-1/2" Pipe	P/N: TB-0333
37-1/2 Degree Bevel Bit 3" to 4" Pipe	P/N: TB-0944
37-1/2 Degree Heavy Duty Bevel Bit 2" to 3-1/2" Pipe	P/N: TB-0333-1
30 Degree Bevel Bit	P/N: TB-3030
45 Degree Bevel Bit	P/N: TB-1273
25-1/2 Degree J-Bevel Bit	P/N: TB-2566
Facing Bit .750" Tall for 1" to 2" Pipe	P/N: TB-0169
Facing Bit .875" Tall for 2" to 3" Pipe	P/N: TB-0257
Facing Bit 1.00" Tall for 3" to 4" Pipe	P/N: TB-0258
4 Degree Chamfer Bit	P/N: TB-0168

### 206 & 212 BEVELING MACHINE

37-1/2 Degree Bevel Bit Lower Range	P/N: TB-2905
37-1/2 Degree Bevel Bit Upper Range	P/N: TB-2906
30 Degree Bevel Bit Lower Range	P/N: TB-2930
45 Degree Bevel Bit Lower Range	P/N: TB-2913
45 Degree Bevel Bit Upper Range	P/N: TB-2914
J-Bevel Bit Lower Range	P/N: TB-2915
J-Bevel Bit Upper Range	P/N: TB-2916
Facing Bit	P/N: TB-2904
C-Bore 14.5 Degree Lower Range	P/N: TB-2907
C-Bore 14.5 Degree Middle Range	P/N: TB-2908
C-Bore 14.5 Degree Upper Range	P/N: TB-2909
C-Bore 10 Degree Lower Range	P/N: TB-2910
C-Bore 10 Degree Middle Range	P/N: TB-2911
C-Bore 10 Degree Upper Range	P/N: TB-2912

### 604 SB THRU 608 SB

	LOW PROFILE		EXTENDED TOOL	
	Sever	Bevel	Sever	Bevel
37-1/2 DOUBLE BEVEL	P/N: TB-1643	P/N: TB-1642	P/N: TB-0467	P/N: TB-1258
37-1/2 RIGHT HAND	P/N: TB-1645	P/N: TB-1644	P/N: TB-0459	P/N: TB-1258
37-1/2 LEFT HAND	P/N: TB-1647	P/N: TB-1646	P/N: TB-0467	P/N: TB-1256
90 LH SEVER	P/N: TB-1638	P/N: TB-1639	P/N: TB-0502	P/N: TB-0501
90 RH SEVER	P/N: TB-1641	P/N: TB-1640	P/N: TB-1023	P/N: TB-1022

### 610 SB THRU 612 SB

	LOW PROFILE		EXTENDED TOOL	
	Sever	Bevel	Sever	Bevel
37-1/2 DOUBLE BEVEL	P/N: TB-0986	P/N: TB-0987	P/N: TB-0467	P/N: TB-1258
37-1/2 RIGHT HAND	P/N: TB-1257	P/N: TB-1266	P/N: TB-0459	P/N: TB-1258
37-1/2 LEFT HAND	P/N: TB-1265	P/N: TB-1264	P/N: TB-0467	P/N: TB-1256
	<b>Leading</b>	<b>Trail</b>	<b>Leading</b>	<b>Trail</b>
90 LH SEVER	P/N: TB-1596	P/N: TB-1595	P/N: TB-0502	P/N: TB-0501
90 RH SEVER	P/N: TB-1597	P/N: TB-1598	P/N: TB-1023	P/N: TB-1022

# TOOL BITS FOR E.H. WACHS BEVELING MACHINE

## SDB & LB MODEL | ¼" SHANK STYLE TOOL BITS

Facing Bit (Standard)	P/N: 26-410-02
Facing Bit (High Range)	P/N: 26-410-03
37 ½" Degree Bevel Bit (Low Range)	P/N: 26-411-01
37 ½" Degree Bevel Bit (Mid Range)	P/N: 26-411-02
37 ½" Degree Bevel Bit (High Range)	P/N: 26-411-03
37 ½" Degree Bevel & Facing Bit (Low Range)	P/N: 26-413-01
37 ½" Degree Bevel & Facing Bit (High Range)	P/N: 26-413-01
I.D. Deburring Tool (Low Range)	P/N: 24-412-01
I.D. Deburring Tool (Mid Range)	P/N: 24-412-02
I.D. Deburring Tool (High Range)	P/N: 24-412-03

## SDB-206 & 412 TOOLING

### Form Tool Inserts

H.S.S 2 Sided Insert for Facing and Beveling	P/N: 56-711-01
H.S.S 2 Sided 3/32 J-Bevel Insert	P/N: 56-711-02
Carbide 2 Sided Insert for Facing and Beveling	P/N: 56-712-01
Carbide 2 Sided 3/32 J-Bevel Insert	P/N: 56-711-02

### I.D. Tool Bits

10 Degree I.D. Deburring Bit, (Low- Range)	P/N: 56-702-01
10 Degree I.D. Deburring Bit, (Mid- Range)	P/N: 56-702-02
10 Degree I.D. Deburring Bit, (High- Range)	P/N: 56-702-03
4:1 Taper Counterbore Bit (Low- Range)	P/N: 56-705-01
4:1 Taper Counterbore Bit (Mid- Range)	P/N: 56-705-02
4:1 Taper Counterbore Bit (High- Range)	P/N: 56-705-03

### Misc. Tool Bits

10 Degree X 37 ½ Degree Bevel Bit	P/N: 56-707-00
Tool Insert for Flange Facing	P/N: 56-710-00



**OTTO TOOL, INC.**

3921 Sandstone Drive, Suite 5 • El Dorado Hills, CA • 95762

Toll Free: 800-878-BITS (2487) • Phone: 916-939-3400 • Fax: 916-939-0912

[www.ottotool.com](http://www.ottotool.com)